



BA BREAKERS &
ATTACHMENTS

Underground Loader Extension Carriage

Product Benefits

- Blasting problems eliminated
- Oversize broken in location
- Continuous operation without pausing for additional blasting
- Draw point availability increased
- Mucking resumes quickly
- No handling/rehandling of oversize
- Productivity increased
- Utilises existing equipment, reducing capital investment
- Safety



TECHNICAL SPECIFICATIONS

Hammers	Epiroc MB1000,MB1200,MB1500,MB1650 and hammers with weight range of 1000-1700kg
Carrier types	LH307, ST315 and other equivalent LHDs
Frame Structures	Welded steel plate structures
Feed movement	600 mm
Pins	Heat treated multi alloy steel pins
Bushings	Special bronze bushings with greasing points
Cylinder	Double acting feed cylinder with self-aligning bearings
Max. Pressure	25 MPa (Hydraulic Pressure)
Rod-Stroke	56-650 (mm)
Weight	1450kg (without hammer)
Control valve	1 proportional section for feed movement, 1 on/off section for the hammer

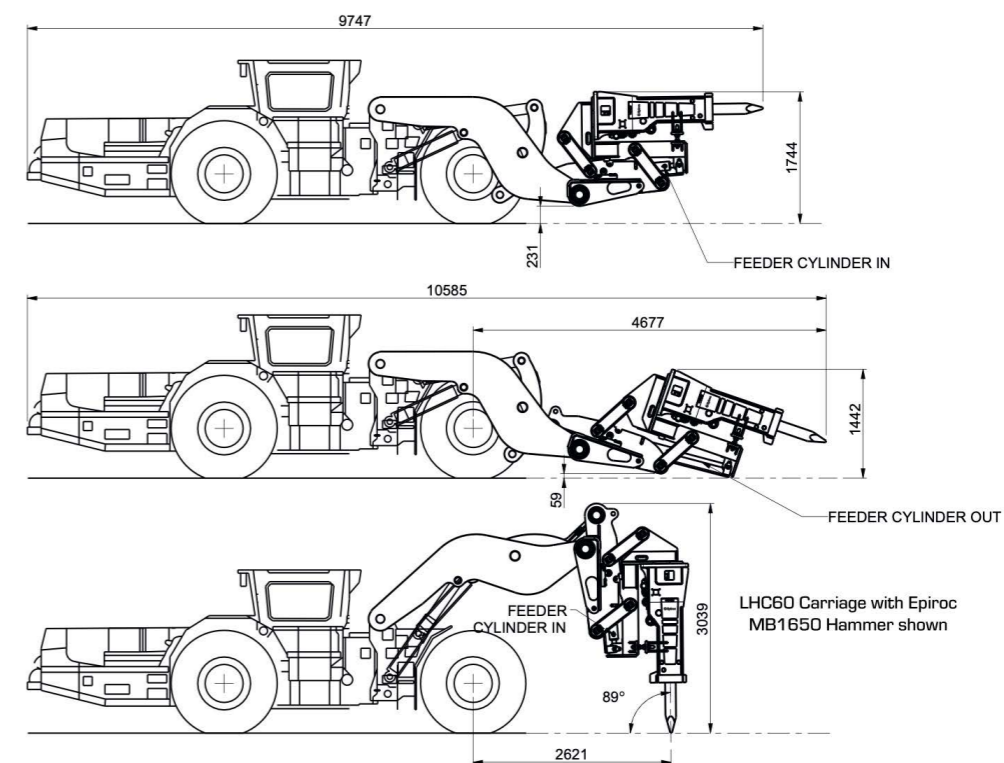

Western Australia: breakerswa@baeg.com.au
 ☎ +61 8 9248 9800 71 Prestige Parade, Wangara
 📍 +61 8 9209 3697 Perth WA 6065

Queensland & NT: breakersqld@baeg.com.au
 ☎ +61 7 3635 7333 76 Dulacca Street, Acacia Ridge
 📍 +61 7 3635 7355 Brisbane QLD 4110

Victoria: breakersvic@baeg.com.au
 ☎ +61 3 9308 8202 32 Freight Drive, Somerton
 📍 +61 3 9308 8872 Melbourne VIC 3062

Product Benefits

- Blasting problems eliminated
- Oversize broken in location
- Continuous operation without pausing for additional blasting
- Draw point availability increased
- Mucking resumes quickly
- No handling/rehandling of oversize
- Productivity increased
- Utilises existing equipment, reducing capital investment
- Safety

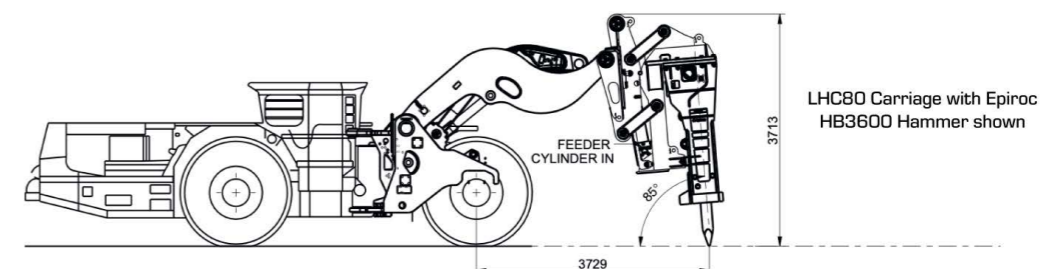
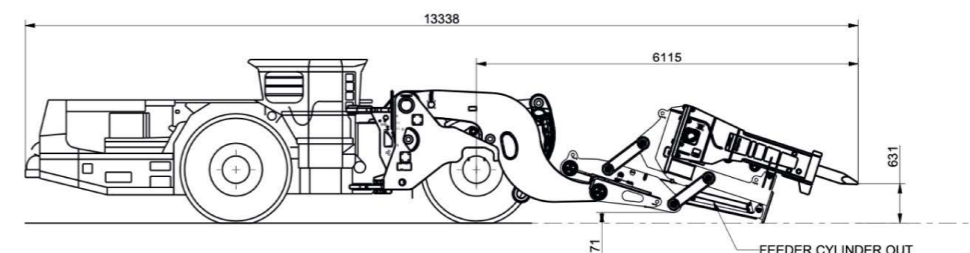
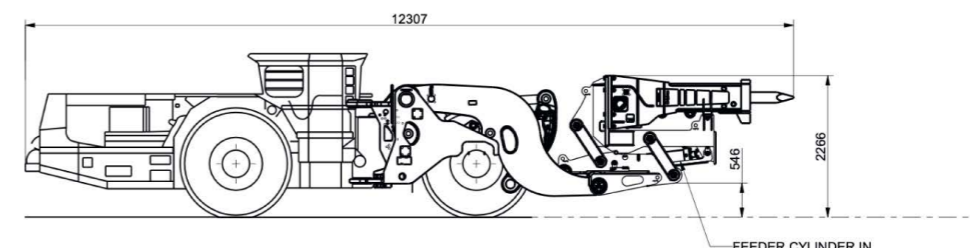

TECHNICAL SPECIFICATIONS

Hammers	Epiroc MB1650, HB2000, HB2500, HB3100, HB3600 or HB4100 and hammers with weight range of 1700-4200kg
Carrier types	ST3.5, T400, LH410, LH514, LH517, LH621, R1600, R1700, ST14 & ST18 and other equivalent LHDs
Frame Structures	Welded steel plate structures
Feed movement	800 mm
Pins	Heat treated multi alloy steel pins
Bushings	Heat treated steel bushings
Cylinder	Double acting feed cylinder with self-aligning bearings
Max. Pressure	25 MPa (Hydraulic Pressure)
Rod-Stroke	900-800 (mm)
Weight	2900kg (without hammer)
Control valve	1 proportional section for feed movement, 1 on/off section for the hammer

Western Australia: breakerswa@baeg.com.au
 ☎ +61 8 9248 9800 71 Prestige Parade, Wangara
 📍 +61 8 9209 3697 Perth WA 6065

Queensland & NT: breakersqld@baeg.com.au
 ☎ +61 7 3635 7333 76 Dulacca Street, Acacia Ridge
 📍 +61 7 3635 7355 Brisbane QLD 4110

Victoria: breakersvic@baeg.com.au
 ☎ +61 3 9308 8202 32 Freight Drive, Somerton
 📍 +61 3 9308 8872 Melbourne VIC 3062

Western Australia:

☎ +61 8 9248 9800

📠 +61 8 9209 3697

71 Prestige Parade
Wangara, Perth
WA 6065

Queensland & NT:

☎ +61 7 3635 7333

📠 +61 7 3635 7355

76 Dulacca Street
Acacia Ridge, Brisbane
QLD 4110

Victoria:

☎ +61 3 9308 8202

📠 +61 3 9308 8872

32 Freight Drive
Somerton, Melbourne
VIC 3062

www.BAEG.com.au

BA BREAKERS &
ATTACHMENTS

